

# EXPLORER PERFORMANCE

## BRIDGE COORDINATE MEASURING MACHINE



# EXPLORER PERFORMANCE ACCURATE AND POWERFUL

Combining breakthrough design, proven construction and controller technology, and today's most advanced measurement software and multisensor systems, Explorer Performance provides comprehensive optimisation for your measuring solution.

Equipped with the newest controller system, advanced temperature compensation system, powerful PC-DMIS software and multi-probe system, Explorer Performance brings you an unparalleled user experience.



# PROVEN TECHNOLOGY

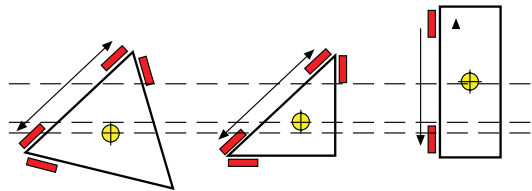

Patented TRICISION® bridge design with wider bearing separation, a lower centre of gravity and lighter weight than a conventional bridge coordinate measuring machine (CMM) beam.



European-import, high-precision optical scales installed with one end fixed and the other freely extensible.



The patented design improves the dynamic characteristics of the machine and ensures the safety of the Z axis.

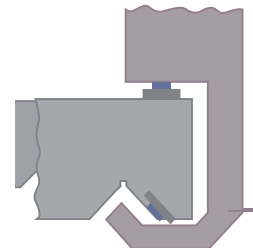

Integral dovetail guideway on Y axis enhances the performance.

Patented TRICISION design with triangular cross section which provides optimum stiff-to-mass ratio for unquestioned precision and long-term stability.



Patented counterbalance design improves measuring performance.

Remote mounted drive motors reduce moving mass for faster setting, dissipating heat away from the machine frame.

Heidenhain high-resolution METALLUR® scales with PTB-certified thermal expansion coefficient.

All three axes run on high-precision self-cleaning air bearings, providing smooth movement that reduces wear on the guideways.

Heavy, stable granite table resists vibrations.

Multi-probing technology supporting a wide range of applications.

One-piece table construction, patented dovetail guideways are precision-machined in granite to improve accuracy and repeatability.

## PERFECT CONFIGURATION PROBING SYSTEM AND MEASUREMENT SOFTWARE

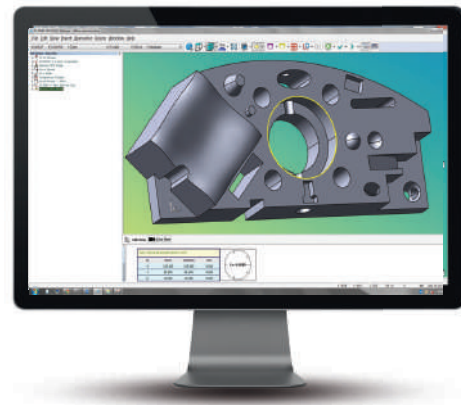

As the cost-effective measuring machine series, based on the multi-probing technology, Explorer Performance supports a wide range of applications, from point-to-point to the most demanding contact or non-contact scanning measurements.

The HP-S-X1 is a high accuracy 3D scanning probe that can rapidly and automatically collect thousands of data points for the complete and precise evaluation of all part features, including form, location and size. It supports both single point probing and continuous scanning. Also available is the self-centring mode, which is particularly useful for measuring gears. Like the other scanning probes, the HP-S-X1 provides simultaneous and unclamped probing in all axes, always orthogonal to the contact surface.

The HH-A/HH-AS is a motorised indexable probe head featuring high speed operation and high rotational torque. This fully motorised, highly accurate probe head is the universal system component for use with any multicoordinate measuring machine, whatever the model or manufacturer. It can be used with extension bars up to 300 mm long.

PC-DMIS is the world's leading coordinate measurement machine software with over 70 000 seats in place worldwide. Use its powerful capabilities to measure everything from simple prismatic parts to the most complex aerospace and automotive components.

Designed to enable users to perform simple inspection operations without CAD data, PC-DMIS PRO features an easy-to-use graphical user interface. Quick Start routines for probe calibration, part alignment and reporting allow operators to efficiently create part programs and perform the measurement tasks.

PC-DMIS CAD is ideal for manufacturers of prismatic parts that want to integrate CAD into inspection operations. It allows users to program and inspect parts using CAD models ranging from simple 2D blueprints through to full 3D solid models.

PC-DMIS CAD++ enables users to measure complex parts. It includes all the capabilities of PC-DMIS CAD and adds the ability to measure complex, contoured surfaces including thin-walled sheet metal, plastic, blades, dies and moulds.

## EXPLORER PERFORMANCE 06.XX.06,08.XX.06 SPECIFICATIONS

Models	MPE( $\mu$ m), L(mm)										Max. 3D Speed (mm/s)	Max. 3D Accel (mm/s <sup>2</sup> )
	HP-T/HP-TM		TP200		HP-S-X1/HP-S-X3C			HP-S-X1/HP-S-X3C + X. $\mu$ kit				
	MPE <sub>E</sub> <sup>(1)</sup>	MPE <sub>P</sub> <sup>(2)</sup>	MPE <sub>E</sub> <sup>(1)</sup>	MPE <sub>P</sub> <sup>(2)</sup>	MPE <sub>E</sub> <sup>(1)</sup>	MPE <sub>P</sub> <sup>(2)</sup>	MPE <sub>THP</sub> <sup>(3)</sup>	MPE <sub>E</sub> <sup>(1)</sup>	MPE <sub>P</sub> <sup>(2)</sup>	MPE <sub>THP</sub> <sup>(3)</sup>		
06.xx.06	2.4+3.3L/1000	2.4	2.2+3.3L/1000	2.2	1.9+3.3L/1000	1.9	3.0/68	1.7+3.3L/1000	1.7	3.0/68	520	1730
08.xx.06	2.5+3.3L/1000	2.5	2.3+3.3L/1000	2.3	2.0+3.3L/1000	2.0	3.5/68	1.8+3.3L/1000	1.8	3.5/68	520	1470

- (1) MPE<sub>E</sub> according to ISO 10360-2:2001  
 (2) MPE<sub>P</sub> according to ISO 10360-2:2001  
 (3) MPE<sub>THP</sub> according to ISO 10360-4:2000

Probe configuration for performance test:

- HP-T/HP-TM: standard measuring force, stylus length 10 mm, tip diameter 4 mm
- TP200: standard measuring force, stylus length 10 mm, tip diameter 4 mm
- HP-S-X1/HP-S-X1S/HP-S-X1H/HP-S-X1C: stylus length 50 mm, tip diameter 5 mm
- HP-S-X3C: stylus length 60 mm, tip diameter 4 mm

Performance data are valid if the following specifications are met:

- Temperature range: 18 - 22°C;
- Max. air temperature variation: 1°C/h - 2°C/24h;
- Max. gradient in space: 1°C/m
- Relative humidity: 25% - 75%

## EXPLORER PERFORMANCE 06.XX.06,08.XX.06 STROKES, DIMENSIONS AND WEIGHTS

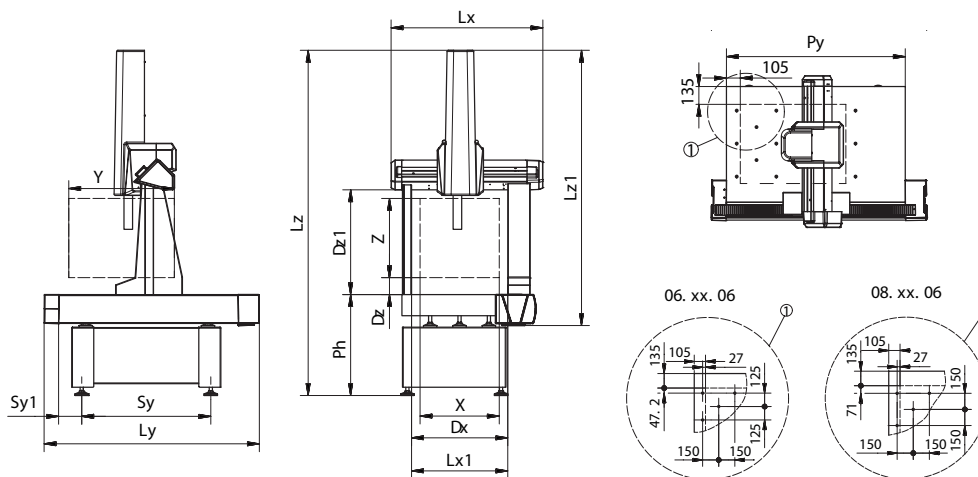

Models	Strokes (mm)			Overall Dimensions (mm)			Daylights (mm)			Max. Part Weight (kg)	CMM Weight (kg)
	X	Y	Z	Lx	Ly	Lz	Dx	Dz	Dz1		
06.08.06	600	800	600	1150	1623	2638	734	144	794	300	730
06.10.06	600	1000	600	1150	1823	2658	734	144	794	300	890
08.10.06	800	1000	600	1350	1823	2658	934	144	794	500	1074
08.12.06	800	1200	600	1350	2023	2658	934	144	794	500	1196

## TECHNICAL CHARACTERISTICS

<p><b>Mechanical Frame</b></p> <p>X and Z: micromachined anodised light alloy extrusion                      Y: integral dovetail guideways, machined into the table</p>	<p><b>Surface Plate</b></p> <p>Material: granite                      Part locking: threaded inserts M8 x 1.25</p>	<p><b>Measuring System</b></p> <p>METALLUR linear scales                      System resolution: 0.005<math>\mu</math>m</p>
<p><b>Environment</b></p> <p>Temperature range: 10 - 45 °C                      Relative humidity: 90%, non-condensing</p>	<p><b>Thermal Compensation</b></p> <p>Linear: 18 - 22 °C</p>	<p><b>Air Supply</b></p> <p>Minimum air supply pressure: 5 bar                      Air consumption: 90NL/min</p>
<p><b>Sliding System</b></p> <p>Air bearing on all axes</p>	<p><b>Ram Counterbalance</b></p> <p>Pneumatic, adjustable</p>	<p><b>Power</b></p> <p>Voltage: 220 V/50Hz</p>

## EXPLORER PERFORMANCE 10.XX.08 SPECIFICATIONS

Models	MPE(μm), L(mm)										Max.3D Speed (mm/s)	Max. 3D Accel (mm/s <sup>2</sup> )
	HP-T/HP-TM		TP200		HP-S-X1/HP-S-X3C			HP-S-X1/HP-S-X3C + X.μ kit				
	MPE <sub>E</sub> <sup>(1)</sup>	MPE <sub>P</sub> <sup>(2)</sup>	MPE <sub>E</sub> <sup>(1)</sup>	MPE <sub>P</sub> <sup>(2)</sup>	MPE <sub>E</sub> <sup>(1)</sup>	MPE <sub>P</sub> <sup>(2)</sup>	MPE <sub>THP</sub> <sup>(3)</sup>	MPE <sub>E</sub> <sup>(1)</sup>	MPE <sub>P</sub> <sup>(2)</sup>	MPE <sub>THP</sub> <sup>(3)</sup>		
10.xx.08	2.7+3.3L/1000	2.7	2.5+3.3L/1000	2.5	2.3+3.3L/1000	2.3	4.0/68	2.0+3.3L/1000	2.0	4.0/68	520	1470

(1) MPE<sub>E</sub> according to ISO 10360-2:2001

(2) MPE<sub>P</sub> according to ISO 10360-2:2001

(3) MPE<sub>THP/T</sub> according to ISO 10360-4:2000

Probe configuration for performance test:

- HP-T/HP-TM: standard measuring force, stylus length 10 mm, tip diameter 4 mm
- TP200: standard measuring force, stylus length 10 mm, tip diameter 4 mm
- HP-S-X1/HP-S-X1S/HP-S-X1H/HP-S-X1C: stylus length 50 mm, tip diameter 5 mm
- HP-S-X3C: stylus length 60 mm, tip diameter 4 mm

Performance data are valid if the following specifications are met:

- Temperature range: 18 - 22°C;
- Max. air temperature variation: 1°C/h - 2°C/24h;
- Max. gradient in space: 1°C/m
- Relative humidity: 25% - 75%

## EXPLORER PERFORMANCE 10.XX.08 STROKES, DIMENSIONS AND WEIGHTS

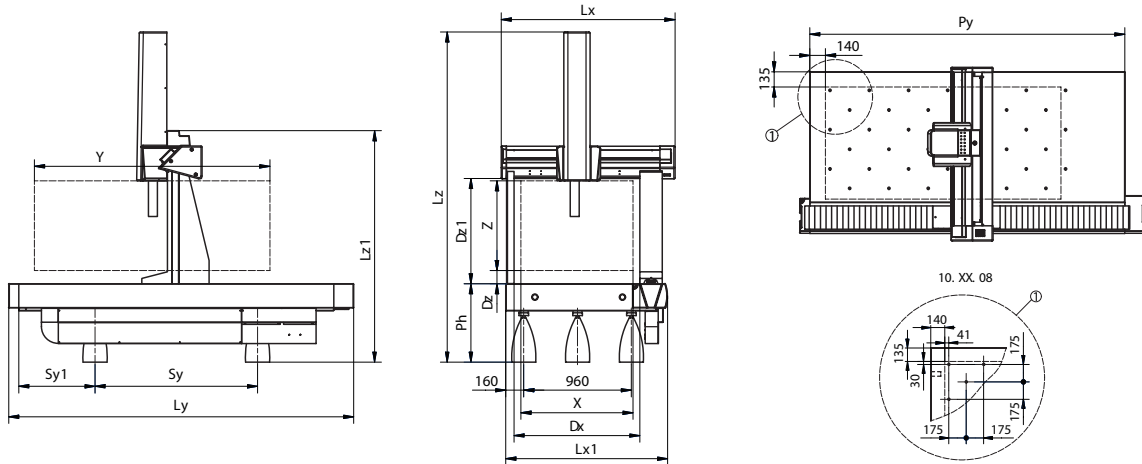

Models	Strokes (mm)			Overall Dimensions (mm)			Daylights (mm)			Max. Part Weight (kg)	CMM Weight (kg)
	X	Y	Z	Lx	Ly	Lz	Dx	Dz	Dz1		
10.12.08	1000	1200	800	1600	2177	2936	1130	118	940	1300	1785
10.15.08	1000	1500	800	1600	2477	2946	1130	118	940	1500	2090
10.21.08	1000	2100	800	1600	3077	2946	1130	118	940	1800	2625

## TECHNICAL CHARACTERISTICS

<p><b>Mechanical Frame</b></p> <p>X and Z: micromachined anodised light alloy extrusion Y: integral dovetail guideways, machined into the table</p>	<p><b>Surface Plate</b></p> <p>Material: granite Part locking: threaded inserts M8x 1.25</p>	<p><b>Measuring System</b></p> <p>METALLUR linear scales System resolution: 0.005μm</p>
<p><b>Environment</b></p> <p>Temperature range: 10 - 45 °C Relative humidity: 90%, non-condensing</p>	<p><b>Thermal Compensation</b></p> <p>Linear: 18 - 22 °C</p>	<p><b>Air Supply</b></p> <p>Minimum air supply pressure: 5 bar Air consumption: 90NL/min</p>
<p><b>Sliding System</b></p> <p>Air bearing on all axes</p>	<p><b>Ram Counterbalance</b></p> <p>Pneumatic, adjustable</p>	<p><b>Power</b></p> <p>Voltage: 220 V/50Hz</p>

## EXPLORER PERFORMANCE 12.XX.10 SPECIFICATIONS

Models	MPE(μm), L(mm)										Max. 3D Speed (mm/s)	Max. 3D Accel (mm/s <sup>2</sup> )
	HP-T/HP-TM		TP200		HP-S-X1/HP-S-X3C			HP-S-X1/HP-S-X3C + X.μ kit				
	MPE <sub>E</sub> <sup>(1)</sup>	MPE <sub>P</sub> <sup>(2)</sup>	MPE <sub>E</sub> <sup>(1)</sup>	MPE <sub>P</sub> <sup>(2)</sup>	MPE <sub>E</sub> <sup>(1)</sup>	MPE <sub>P</sub> <sup>(2)</sup>	MPE <sub>THP</sub> <sup>(3)</sup>	MPE <sub>E</sub> <sup>(1)</sup>	MPE <sub>P</sub> <sup>(2)</sup>	MPE <sub>THP</sub> <sup>(3)</sup>		
12.15.10	3.0+3.3L/1000	3.0	2.8+3.3L/1000	2.8	2.6+3.3L/1000	2.6	5.0/68	2.4+3.3L/1000	2.4	5.0/68	433	1000
12.22.10	3.0+3.3L/1000	3.0	2.8+3.3L/1000	2.8	2.6+3.3L/1000	2.6	5.0/68	2.4+3.3L/1000	2.4	5.0/68	433	1000
12.30.10	3.0+3.3L/1000	3.0	2.8+3.3L/1000	2.8	2.6+3.3L/1000	2.6	5.0/68	2.4+3.3L/1000	2.4	5.0/68	433	1000

(1) MPE<sub>E</sub> according to ISO 10360-2:2001

(2) MPE<sub>P</sub> according to ISO 10360-2:2001

(3) MPE<sub>THP</sub> according to ISO 10360-4:2000

Probe configuration for performance test:

- HP-T/HP-TM: standard measuring force, stylus length 10 mm, tip diameter 4 mm
- TP200: standard measuring force, stylus length 10 mm, tip diameter 4 mm
- HP-S-X1/HP-S-X1S/HP-S-X1H/HP-S-X1C: stylus length 50 mm, tip diameter 5 mm
- HP-S-X3C: stylus length 60 mm, tip diameter 4 mm

Performance data are valid if the following specifications are met:

- Temperature range: 18 - 22°C;
- Max. air temperature variation: 1°C/h - 2°C/24h;
- Max. gradient in space: 1°C/m
- Relative humidity: 25% - 75%

## EXPLORER PERFORMANCE 12.XX.10 STROKES, DIMENSIONS AND WEIGHTS

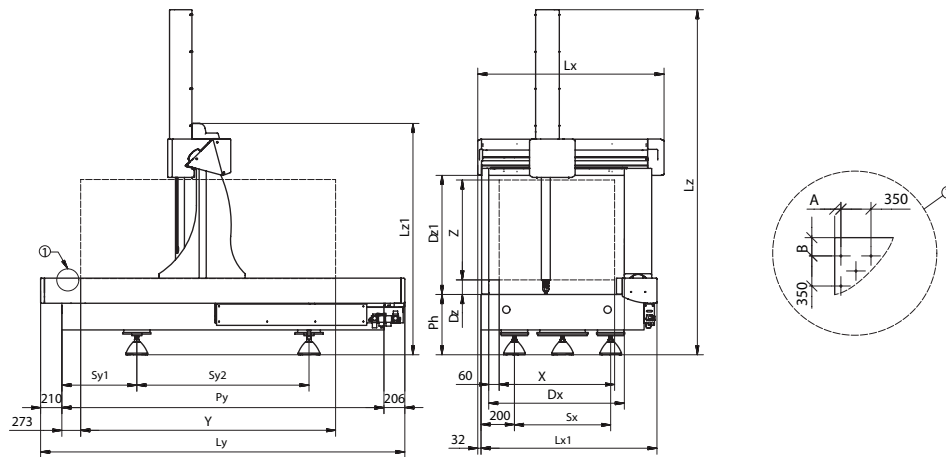

Models	Strokes (mm)			Overall Dimensions (mm)			Daylights (mm)			Max. Part Weight (kg)	CMM Weight (kg)
	X	Y	Z	Lx	Ly	Lz	Dx	Dz	Dz1		
12.15.10	1200	1500	1000	1838	2896	3407	1339	150	1173	1800	3792
12.22.10	1200	2200	1000	1838	3596	3407	1339	150	1173	2250	5696
12.30.10	1200	3000	1000	1838	4396	3437	1339	150	1173	2250	7637

## TECHNICAL CHARACTERISTICS

<b>Mechanical Frame</b> X and Z: micromachined anodised light alloy extrusion Y: integral dovetail guideways, machined into the table	<b>Surface Plate</b> Material: granite Part locking: threaded inserts M8 x 1.25	<b>Measuring System</b> METALLUR linear scales System resolution: 0.005μm
<b>Environment</b> Temperature range: 10 - 45 °C Relative humidity: 90%, non-condensing	<b>Thermal Compensation</b> Linear: 18 - 22 °C	<b>Air Supply</b> Minimum air supply pressure: 5 bar Air consumption: 90NL/min
<b>Sliding System</b> Air bearing on all axes	<b>Ram Counterbalance</b> Pneumatic, adjustable	<b>Power</b> Voltage: 220 V/50Hz





# HEXAGON

MANUFACTURING INTELLIGENCE

Hexagon Manufacturing Intelligence helps industrial manufacturers develop the disruptive technologies of today and the life-changing products of tomorrow. As a leading metrology and manufacturing solution specialist, our expertise in sensing, thinking and acting – the collection, analysis and active use of measurement data – gives our customers the confidence to increase production speed and accelerate productivity while enhancing product quality.

Through a network of local service centres, production facilities and commercial operations across five continents, we are shaping smart change in manufacturing to build a world where quality drives productivity. For more information, visit [HexagonMI.com](http://HexagonMI.com).

Hexagon Manufacturing Intelligence is part of Hexagon (Nasdaq Stockholm: HEXA B; [hexagon.com](http://hexagon.com)), a leading global provider of information technologies that drive quality and productivity across geospatial and industrial enterprise applications.

-  COORDINATE MEASURING MACHINES
-  3D LASER SCANNING
-  SENSORS
-  PORTABLE MEASURING ARMS
-  SERVICES
-  LASER TRACKERS & STATIONS
-  MULTISENSOR & OPTICAL SYSTEMS
-  WHITE LIGHT SCANNERS
-  METROLOGY SOFTWARE SOLUTIONS
-  CAD / CAM
-  STATISTICAL PROCESS CONTROL
-  AUTOMATED APPLICATIONS
-  MICROMETERS, CALIPERS AND GAUGES
-  DESIGN AND COSTING SOFTWARE