

# GLOBAL S





# GLOBAL S

## The Coordinate Measuring Machine that Pushes Productivity Further

The GLOBALS coordinate measuring machine (CMM) series from Hexagon Manufacturing Intelligence combines smart technologies delivering superior measurement performance and enhanced productivity for the unique needs of any production environment. Designed by Pininfarina and powered by Hexagon's Enhanced Productivity Series (EPS) concept, GLOBALS brings together enhanced technologies to form an optimal measurement solution

with three performance levels: Green, Blue and Chrome, to suit the requirements of any application. EPS machines offer customers the option to select their main productivity driver and configure the CMM for throughput, precision, flexibility or shop floor capability. The CMM range also supports fully-customised setups to ensure that GLOBALS is universally applicable and drives continuous productivity improvements.

### GLOBAL S- HOW TO CHOOSE THE RIGHT SYSTEM

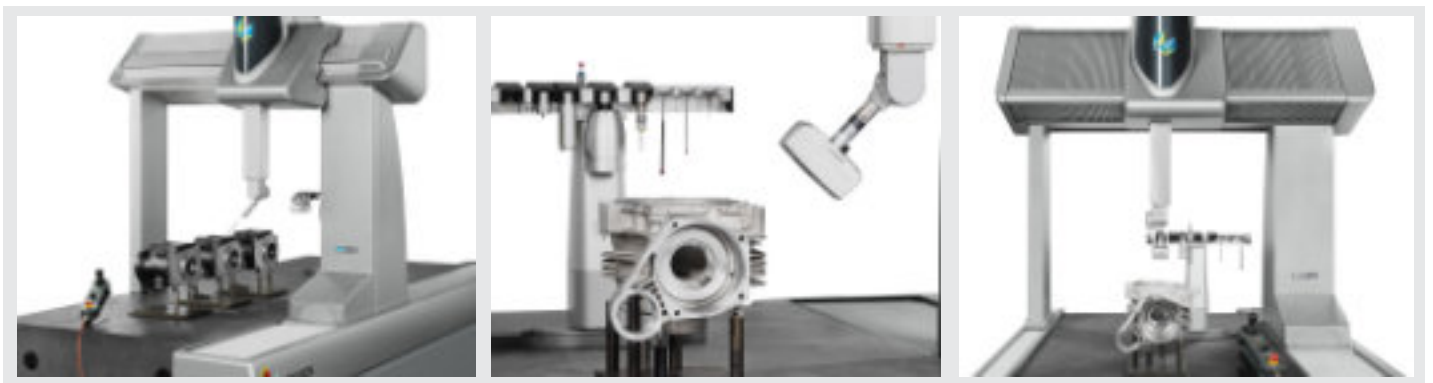
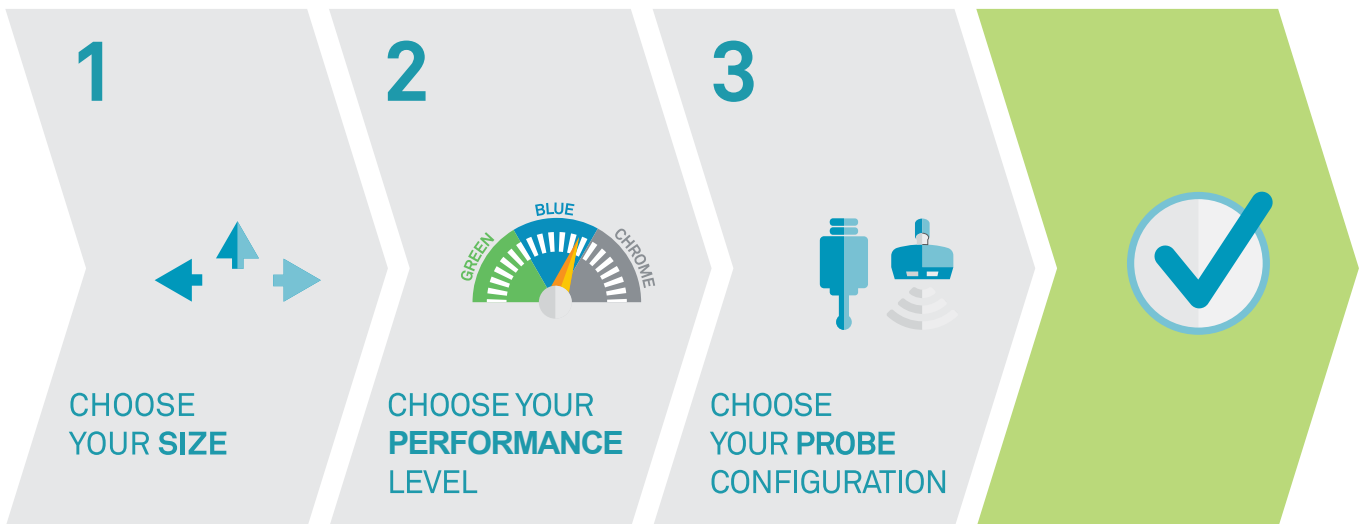



# GLOBALS 05.YY.05: OVERALLDIMENSIONS

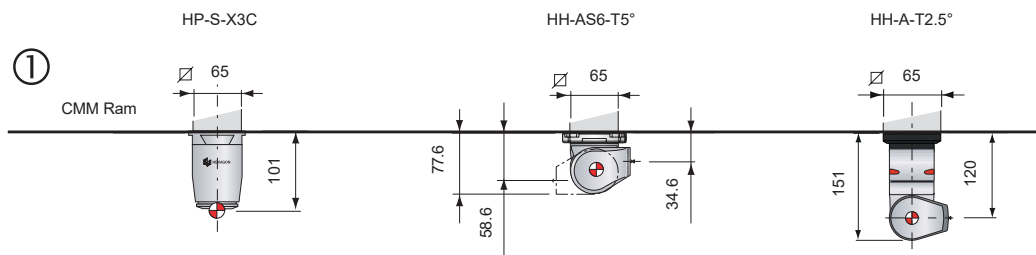
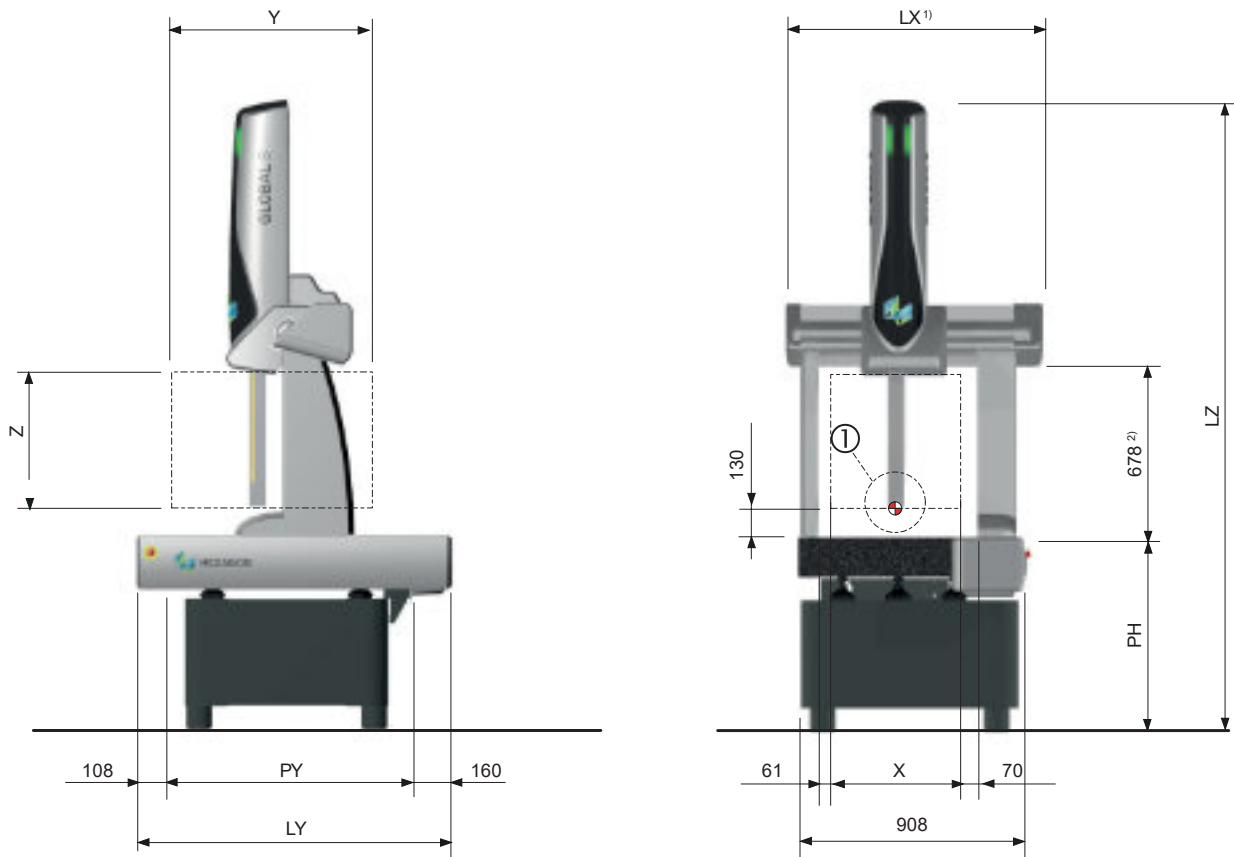

Models	Measuring Range (mm)			Overall Dimensions (mm)			Surface Plate (mm)		Max. Part Weight (kg)	CMM Weight approx. (kg)
	X	Y	Z	LX <sup>1)</sup>	LY	LZ	PH	PY		
05.05.05	500	500	500	1024	1255	2540	800	990	230	510
05.07.05	500	700	500	1024	1455	2540	800	1190	230	625

<sup>1)</sup> With Shop Floor bellows: LX+ 21 mm

<sup>2)</sup> With Shop Floor bellows: 649 mm



# GLOBALS 07.YY.05AND 07.10.07: OVERALLDIMENSIONS

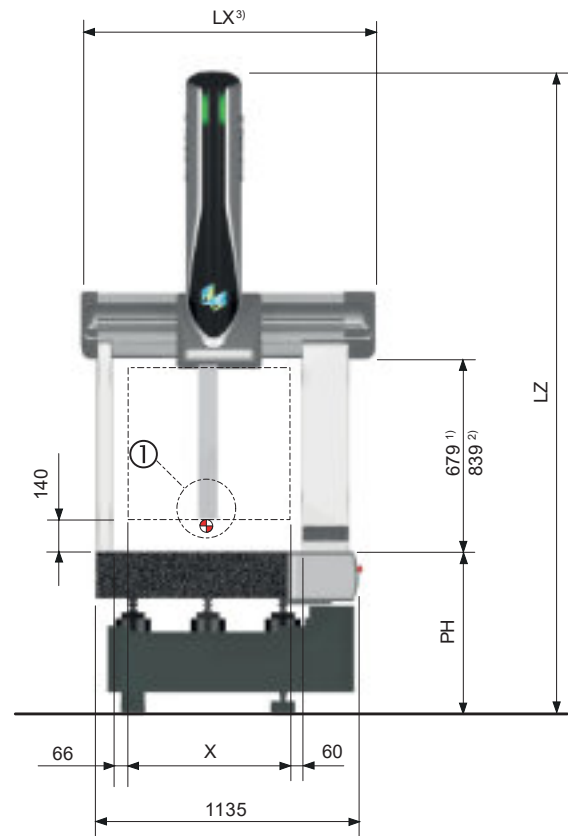
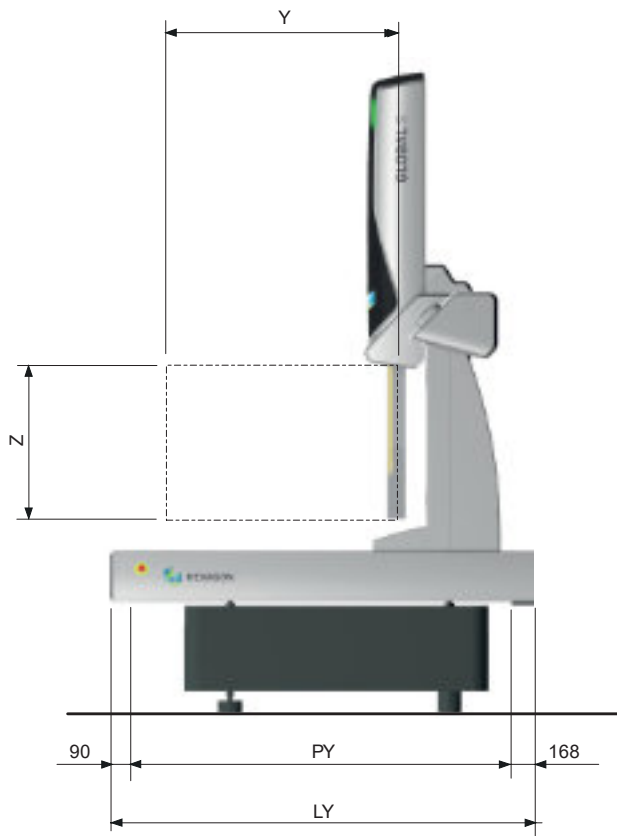

①  
CMM Ram

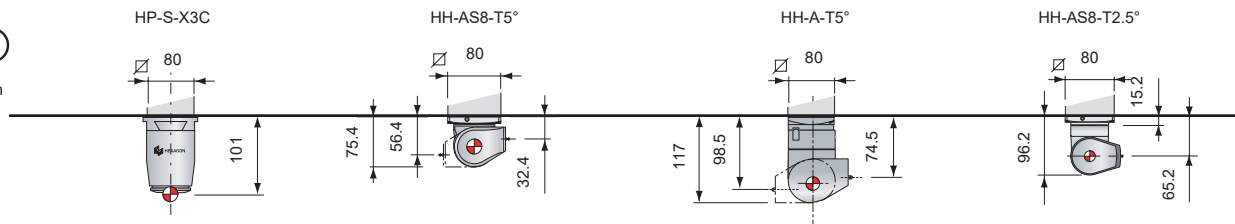

Models	Measuring Range (mm)			Overall Dimensions (mm)			Surface Plate (mm)		Max. Part Weight (kg)	CMM Weight approx. (kg)
	X	Y	Z	LX <sup>3)</sup>	LY	LZ	PH	PY		
07.07.05	700	700	500	1277	1608	2438	680	1350	900	960
07.10.05	700	1000	500	1277	1908	2458	700	1650	900	1245
07.10.07	700	1000	660	1277	1908	2777	700	1650	900	1265

<sup>1)</sup> GLOBALS 07.YY.05- With Shop Floor bellows: 639 mm  
<sup>2)</sup> GLOBALS 07.YY.07- With Shop Floor bellows: 796 mm  
<sup>3)</sup> With Shop Floor packages: LX+ 12 mm

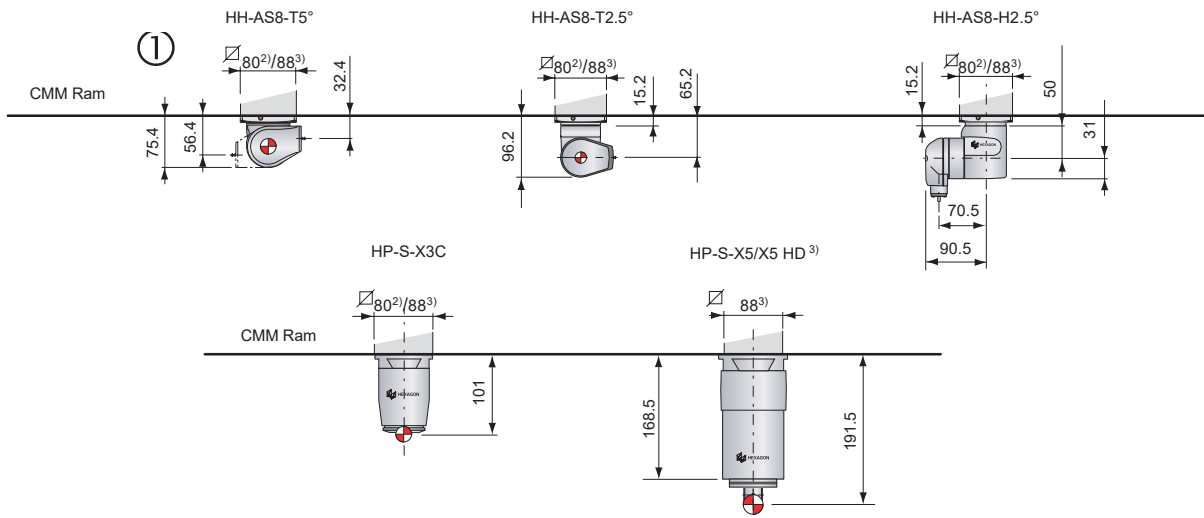
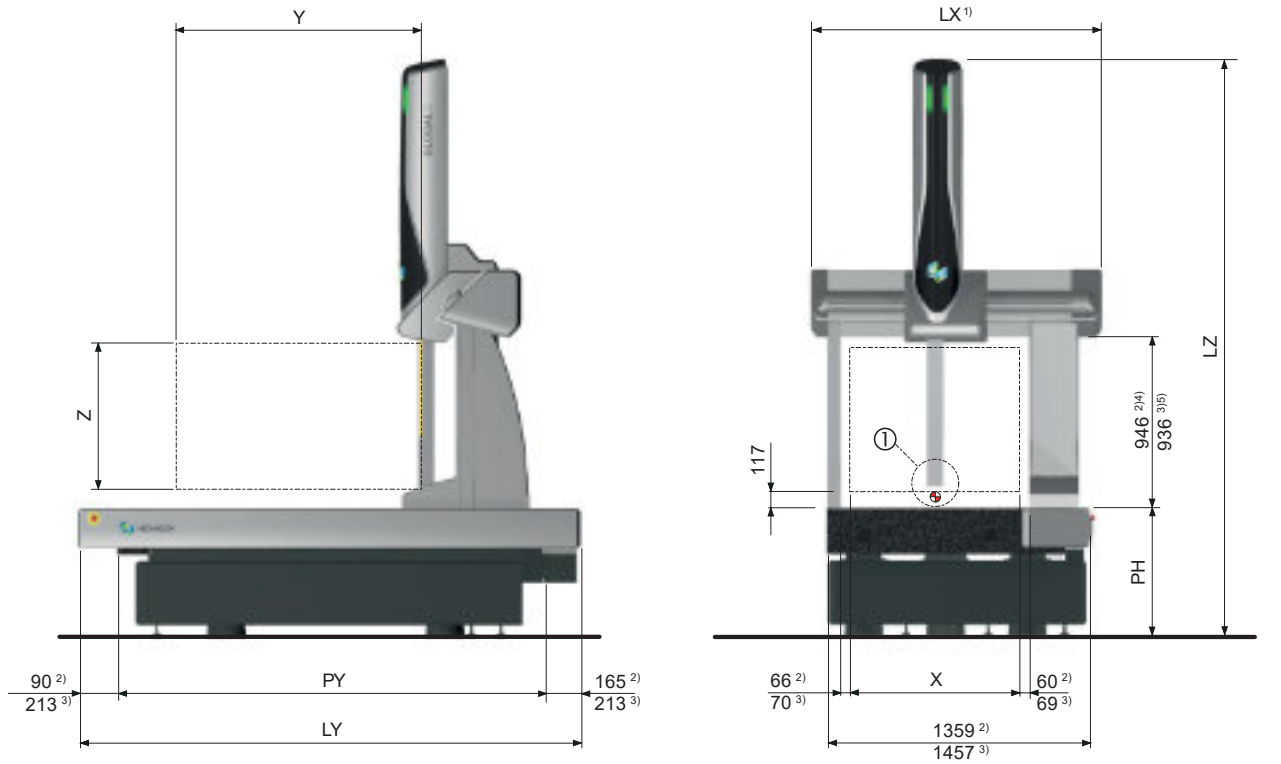

Models	Measuring Range (mm)			Overall Dimensions (mm)			Surface Plate (mm)		Max. Part Weight (kg)	CMM Weight approx. (kg)
	X	Y	Z <sup>6)</sup>	LX <sup>1)</sup>	LY	LZ	PH	PY		
09.12.08	900	1200	800	1477 <sup>2)</sup>	2165 <sup>2)</sup>	3027 <sup>2)</sup>	700	1910 <sup>2)</sup>	1300	1700 <sup>2)</sup>
				1598 <sup>3)</sup>	2455 <sup>3)</sup>	3150 <sup>3)</sup>		2030 <sup>3)</sup>		2350 <sup>3)</sup>
09.15.08	900	1500	800	1477 <sup>2)</sup>	2465 <sup>2)</sup>	3027 <sup>2)</sup>	700	2210 <sup>2)</sup>	1500	1900 <sup>2)</sup>
				1598 <sup>3)</sup>	2755 <sup>3)</sup>	3150 <sup>3)</sup>		2330 <sup>3)</sup>		2650 <sup>3)</sup>
09.20.08	900	2000	800	1477 <sup>2)</sup>	2965 <sup>2)</sup>	3027 <sup>2)</sup>	700 <sup>2)</sup>	2710 <sup>2)</sup>	1800	2300 <sup>2)</sup>
				1598 <sup>3)</sup>	3255 <sup>3)</sup>	3175 <sup>3)</sup>	725 <sup>3)</sup>	2830 <sup>3)</sup>		3350 <sup>3)</sup>

<sup>1)</sup> With Shop Floor bellows: LX+ 16 mm

<sup>2)</sup> GLOBAL S Green

<sup>3)</sup> GLOBALS Blue and Chrome

<sup>4)</sup> With Shop Floor bellows: 906 mm

<sup>5)</sup> With Shop Floor bellows: 922 mm

<sup>6)</sup> With HP-S-X5/H5HD probe head, Z travel = 730 mm



## GLOBALS 12.YY.10: OVERALL DIMENSIONS

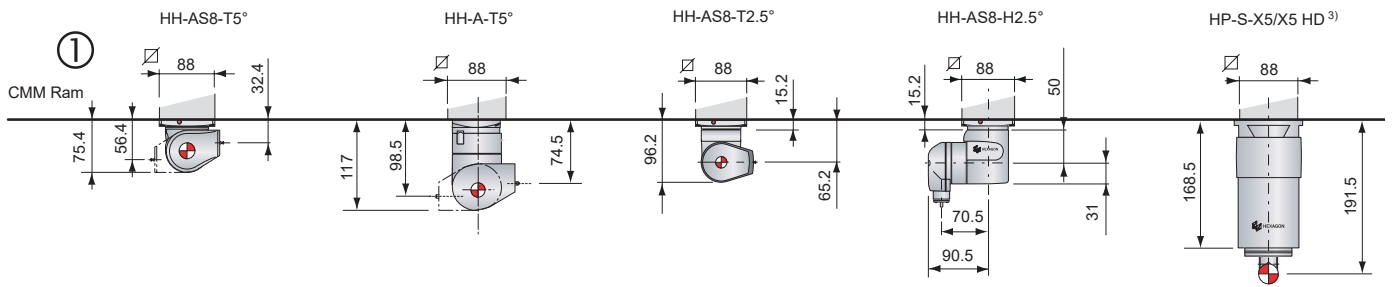
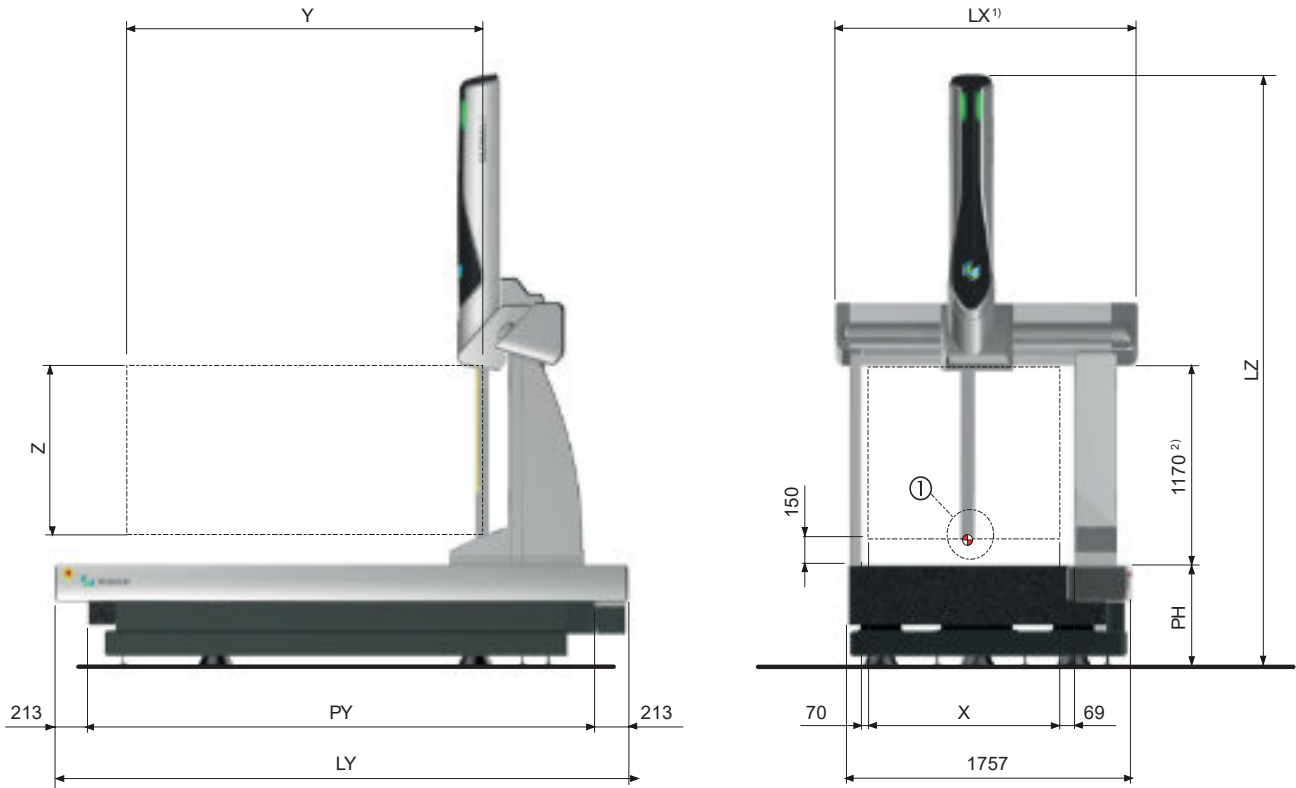

Models	Measuring Range (mm)			Overall Dimensions (mm)			Surface Plate (mm)		Max. Part Weight (kg)	CMM Weight approx. (kg)
	X	Y	Z <sup>4)</sup>	LX <sup>1)</sup>	LY	LZ	PH	PY		
12.15.10	1200	1500	1000	1898	2905	3513	625	2480	1800	3850
12.22.10	1200	2200	1000	1898	3605	3488	600	3180	2250	5750
12.30.10	1200	3000	1000	1898	4405	3513	625	3980	2250	7650

<sup>1)</sup> With Shop Floor bellows: LX+ 17 mm

<sup>2)</sup> With Shop Floor bellows: 1162 mm

<sup>3)</sup> GLOBALS Blue and Chrome

<sup>4)</sup> With HP-S-X5/X5HD probe head, Z travel = 970 mm



Scanning probe heads HP-S-X5/X3  
Articulating head with HP-S-X1 scanning probe

	05.YY.05	07.YY.05	07.YY.07	09.YY.08	12.YY.10
MPE(E0/E150) <sup>1)</sup> - (18 °C- 22 °C)	1.4+ L/333	1.3+ L/333	1.3+ L/333	1.3+ L/333	2.0+ L/333
MPE(E0/E150) <sup>1)</sup> - (16 °C- 26 °C)	1.6+ L/222	1.5+ L/250	1.5+ L/250	1.6+ L/250	2.4+ L/200
MPL(R0)	1.2	1.2	1.2	1.2	1.7
MPE(PFTU)	1.4	1.4	1.4	1.3	1.7
MPE(THP)/MPT(τ)- High accuracy <sup>2)</sup>	2.1/30	2.0/30	2.0/30	2.0/35	2.5/35
MPE(THP)/MPT(τ)-High throughput <sup>2)</sup>	2.1/30	2.0/30	2.0/30	2.3/25	3.5/25
MPE(THN)/MPT(τ)-Non-predefined path <sup>2)</sup>	2.1/50	2.0/50	2.0/50	2.0/50	2.0/50
RONt (MZCI) <sup>3)</sup>	1.4	1.4	1.4	1.4	1.7

MPE(E0/E150) <sup>1)</sup> - (18 °C- 22 °C)	1.4+ L/333	1.4+ L/333	1.4+ L/333	1.4+ L/333	2.1+ L/333
MPE(E0/E150) <sup>1)</sup> - (16 °C- 26 °C)	1.6+ L/222	1.6+ L/250	1.6+ L/250	1.7+ L/250	2.5+ L/200
MPE(E0/E150) <sup>1)</sup> - (16 °C- 26 °C) <sup>4)</sup>	–	1.4+ L/294	1.4+ L/294	1.4+ L/285	2.1+ L/277
MPE(E0/E150) <sup>1)</sup> - (15 °C- 30 °C) <sup>4)</sup>	–	1.4+ L/263	1.4+ L/263	1.4+ L/256	2.1+ L/250
MPL(R0)	1.2	1.2	1.2	1.2	1.7
MPE(PFTU)	1.4	1.4	1.4	1.4	1.8
MPE(THP)/MPT(τ) <sup>2)</sup>	2.5/45	2.5/45	2.5/45	2.5/45	3.1/45

MPE(E0/E150) <sup>1)</sup> - (18 °C- 22 °C)	1.5+ L/333	1.5+ L/333	1.5+ L/333	1.8+ L/333	2.4+ L/333
MPE(E0/E150) <sup>1)</sup> - (16 °C- 26 °C)	1.7+ L/222	1.7+ L/250	1.7+ L/250	2.1+ L/250	2.8+ L/200
MPE(E0/E150) <sup>1)</sup> - (16 °C- 26 °C) <sup>4)</sup>	–	1.5+ L/294	1.5+ L/294	–	–
MPE(E0/E150) <sup>1)</sup> - (15 °C- 30 °C) <sup>4)</sup>	–	1.5+ L/263	1.5+ L/263	–	–
MPL(R0)	1.4	1.4	1.4	1.7	1.9
MPE(PFTU)	1.6	1.6	1.6	1.8	2.4
MPE(THP)/MPT(τ) <sup>2)</sup>	2.9/45	2.9/45	2.9/45	2.9/45	4.0/45

Chrome Performance Level
  Blue Performance Level
  Green Performance Level

Max. Permissible Error MPE (µm) and Max. Permissible Limit MPL (µm) according to ISO10360-2:2009:

- Volumetric length measuring error: MPE(E0/E150)
- Repeatability range: MPL(R0)

Max. Permissible Error MPE (µm) according to ISO10360-5:2010:

- Single stylus form error: MPE(PFTU)

Max. Permissible Error MPE (µm) and Max. Permissible Time MPT(s) according to ISO10360-4: 2000:

- Single stylus form error, scanning: MPE(THP)/MPT(τ)
- Single stylus form error, scanning - Non-predefined path: MPE(THN)/MPT(t)

ISO12181-1: 2011 (VDI/VDE2617 part 2.2): Form measurement error (µm): RONt (MZCI)

Probe Configuration:

- HP-S-X5/3C: stylus length 60 mm, tip diameter 5 mm
- HP-S-X1: stylus length 50 mm, tip diameter 5 mm

<sup>1)</sup>MPE(E0/E150) specifications are to be formally understood as MPE(E0/E150)\* for the case where non-normal CTE material calibrated test lengths are used. Length unit measure (L) in mm.

<sup>2)</sup>MPE(THP/THN) and MPT(τ): test sphere placed in the centre of measuring volume

<sup>3)</sup>RONt test on Ø50 mm ring gauge. Ring axis parallel to machine vertical axis, gauge placed in the centre of measuring volume

<sup>4)</sup>For Shop Floor packages only.





Articulating head with HP-THD/ TP200 high precision trigger probe

	05.YY.05	07.YY.05	07.YY.07	09.YY.08	12.YY.10
MPE(E0/E150) <sup>1)</sup> - (18 °C- 22 °C)	–	1.7+ L/333	1.7+ L/333	1.7+ L/333	2.4+ L/333
MPE(E0/E150) <sup>1)</sup> - (16 °C- 26 °C)	–	1.9+ L/250	1.9+ L/250	1.9+ L/250	2.7+ L/200
MPL(R0)	–	1.7	1.7	1.7	2.7
MPE(PFTU)	–	1.7	1.7	1.7	2.2

MPE(E0/E150) <sup>1)</sup> - (18 °C- 22 °C)	1.7+ L/333	1.7+ L/333	1.7+ L/333	1.9+ L/333	2.5+ L/333
MPE(E0/E150) <sup>1)</sup> - (16 °C- 26 °C)	1.9+ L/222	1.9+ L/250	1.9+ L/250	2.1+ L/250	2.8+ L/200
MPE(E0/E150) <sup>1)</sup> - (16 °C- 26 °C) <sup>2)</sup>	–	1.7+ L/294	1.7+ L/294	1.9+ L/285	2.5+ L/277
MPE(E0/E150) <sup>1)</sup> - (15 °C- 30 °C) <sup>2)</sup>	–	1.7+ L/263	1.7+ L/263	1.9+ L/256	2.5+ L/250
MPL(R0)	1.9	1.9	1.9	2.1	2.7
MPE(PFTU)	1.9	1.9	1.9	1.9	2.2

MPE(E0/E150) <sup>1)</sup> - (18 °C- 22 °C)	1.7+ L/333	1.7+ L/333	1.7+ L/333	1.9+ L/333	2.5+ L/333
MPE(E0/E150) <sup>1)</sup> - (16 °C- 26 °C)	1.9+ L/222	1.9+ L/250	1.9+ L/250	2.1+ L/250	2.8+ L/200
MPE(E0/E150) <sup>1)</sup> - (16 °C- 26 °C) <sup>2)</sup>	–	1.7+ L/294	1.7+ L/294	–	–
MPE(E0/E150) <sup>1)</sup> - (15 °C- 30 °C) <sup>2)</sup>	–	1.7+ L/263	1.7+ L/263	–	–
MPL(R0)	1.9	1.9	1.9	2.1	2.7
MPE(PFTU)	1.9	1.9	1.9	1.9	2.5

Articulating head with HP-TM trigger probe.

	05.YY.05	07.YY.05	07.YY.07	09.YY.08	12.YY.10
MPE(E0/E150) <sup>1)</sup> - (18 °C- 22 °C)	1.9+ L/333	1.9+ L/333	1.9+ L/333	2.1+ L/333	2.7+ L/333
MPE(E0/E150) <sup>1)</sup> - (16 °C- 26 °C)	2.2+ L/222	2.2+ L/250	2.2+ L/250	2.4+ L/250	3.1+ L/200
MPE(E0/E150) <sup>1)</sup> - (16 °C- 26 °C) <sup>2)</sup>	–	1.9+ L/294	1.9+ L/294	2.1+ L/285	2.7+ L/277
MPE(E0/E150) <sup>1)</sup> - (15 °C- 30 °C) <sup>2)</sup>	–	1.9+ L/263	1.9+ L/263	2.1+ L/256	2.7+ L/250
MPL(R0)	1.9	1.9	1.9	2.1	2.7
MPE(PFTU)	2.0	2.0	2.0	2.0	2.6

MPE(E0/E150) <sup>1)</sup> - (18 °C- 22 °C)	1.9+ L/333	1.9+ L/333	1.9+ L/333	2.1+ L/333	2.7+ L/333
MPE(E0/E150) <sup>1)</sup> - (16 °C- 26 °C)	2.2+ L/222	2.2+ L/250	2.2+ L/250	2.4+ L/250	3.1+ L/200
MPE(E0/E150) <sup>1)</sup> - (16 °C- 26 °C) <sup>2)</sup>	–	1.9+ L/294	1.9+ L/294	–	–
MPE(E0/E150) <sup>1)</sup> - (15 °C- 30 °C) <sup>2)</sup>	–	1.9+ L/263	1.9+ L/263	–	–
MPL(R0)	1.9	1.9	1.9	2.1	2.7
MPE(PFTU)	2.0	2.0	2.0	2.0	2.7

Chrome Performance Level
  Blue Performance Level
  Green Performance Level

Max. Permissible Error MPE (µm) and Max. Permissible Limit MPL (µm) according to ISO10360-2:2009:

- Volumetric length measuring error: MPE(E0/E150)
- Repeatability range: MPL(R0)

Max. Permissible Error MPE (µm) according to ISO10360-5:2010:

- Single stylus form error: MPE(PFTU)

Probe Configuration:

- HP-THD: Standard force module, stylus length 10 mm, tip diameter 4 mm
- TP200: Standard force module, stylus length 10 mm, tip diameter 4 mm
- HP-TM: Standard Force Module, stylus length 10 mm, tip diameter 4 mm

<sup>1)</sup>MPE(E0/E150) specifications are to be formally understood as MPE(E0/E150)\* for the case where non-normal CTE material calibrated test lengths are used. Length unit measure (L) in mm.

<sup>2)</sup>For Shop Floor packages only.



## GLOBAL S:NON CONTACTSENSORS SPECIFICATIONS



	HH-A/HP-L-10.6 <sup>1)</sup>	HH-A/HP-L-20.8 <sup>1)</sup>	HH-A/HP-C-Ve <sup>5)</sup>
<sup>2)</sup> Probing Form Error	22 µm	25 µm	–
<sup>3)</sup> Dispersion	7.5 µm	7.5 µm	–
<sup>4)</sup> $P_{F2D,MPE}$	–	–	10 µm
<sup>4)</sup> $P_{FD2D,MPE}$	–	–	6 µm
<sup>4)</sup> $E_{UV,MPE}$	–	–	4 + 2L µm

<sup>1)</sup>From GLOBALS07.YY.07. Some restrictions to workpiece size and machine configuration may apply when used on GLOBALS07.YY.07

<sup>2)</sup> Maximum Permissible Probing Form Error  $P_{Form,Sph.1x25-Tr.ODS,MPE}$  according to ISO10360-8:2013

<sup>3)</sup> Maximum Permissible Probing Error ( $1\sigma$ ). In a Gaussian error distribution, the Probing Error ( $1\sigma$ ) is the width of the spherical shell that encompasses 34.1% of all the points.

<sup>4)</sup> According to ISO10360-7:2011

<sup>5)</sup> Not available on GLOBALSChrome

## GLOBAL S:THROUGHPUT AND DYNAMICS

	Max. probing frequency (with scanning probes)	Max. 3D Speed	Max. 3D Acceleration
High Dynamics <sup>6)</sup>	1000 point/s	860 mm/s	4300 mm/s <sup>2</sup>
Standard Dynamics			
GLOBALS 05.YY.05 to 09.YY.08	1000 point/s	510 mm/s	1700 mm/s <sup>2</sup>
GLOBALS 12.YY.10	1000 point/s	430 mm/s	1000 mm/s <sup>2</sup>

<sup>6)</sup>Dynamics reduction may apply to meet specific customer and/or local safety requirements

Chrome Performance Level      Blue Performance Level      Green Performance Level

## GLOBAL S:TEMPERATURE SPECIFICATIONS

	Lab Temperature	Extended Temperature	Shop Floor Temperature
Ambient temperature	18 °C± 22 °C	16 °C± 26 °C	15 °C± 30 °C
Max. air temperature variation	1 °C/h - 2 °C/24h	1 °C/h - 5 °C/24h	1 °C/h - 5 °C/24h 2 °C/h - 10 °C/24h <sup>7)</sup>
Max. gradient in space	1 °C/m	1 °C/m	1 °C/m

<sup>7)</sup>Accuracy specifications for this temperature range are available on request.

## PERFORMANCE VERIFICATION

**MPE(E0):** maximum permissible error of length measurement

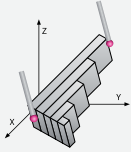

5 gauges have to be measured 3 times with one probing at each end, in 7 different directions. All measuring results must be within MPE(E0).

**MPL(R0):** maximum permissible limit of the repeatability range

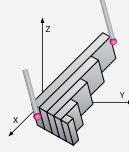

Extreme value of the repeatability range of the length measurement error, calculated by three repeated measurements on each size for a total of 35 values. The 35 repeatability range results must be within MPL(R0).

**MPE(E150):** maximum permissible error of length measurement

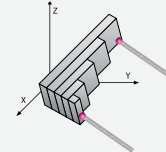

5 length gauges have to be measured 3 times in the YZ- or XZ plane with opposite styli, mounted 150 mm off the Z spindle axis. All measuring results must be within MPE(E150).

**MPE(PFTU):** maximum permissible single stylus form error

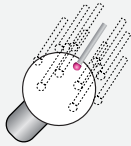

A precision sphere has to be measured with 25 probings. PFTU is the range of all radii. The range of all radii must be within MPE(PFTU).

Maximum permissible scanning probing error

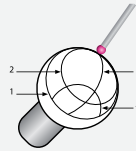

**MPE(THP)/MPT( $\tau$ ):** A precision sphere has to be scanned with 4 defined lines. THP is the range of all radii with the predefined path.  
**MPE(THN)/MPT( $\tau$ ):** A precision sphere has to be scanned with 4 defined lines. THN is the range of all radii with the non-predefined path.  
 The range of all radii and the scanning time must be within MPE(THP/THN) and MPT( $\tau$ ).

**RONt(MZCI):** maximum permissible form measurement error (2D)

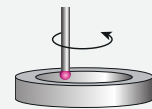

A ring gauge is measured in scanning mode, with high points density. The range of radial distances from two concentric circles enclosing the roundness profile and having the least radial separation, is then evaluated. The range of radial distances must be within RONt.

NOTE: ISO10360-2 test with maximum part weight performed as an option upon request only.



## PROBE HEADS AND SENSORS



Technical Characteristics	HP-S-X3C	HP-S-X5/X5 HD
Overtravel range	± 1.25 mm in all axes	± 2 mm in all axes
Stylus joint	M5	M5
Max. stylus weight	150 g	500 g / 650 g
Max. stylus length	360 mm	500 mm / 800 mm



Technical Characteristics	HH-AS and HH-A-T5° Indexable Probe Head	HH-AS8 and HH-A-T2.5° Indexable Probe Head	HH-AS8-H2.5° Indexable Probe Head
Angular rotation	A axis: +90° / -115° B axis: ±180°	A axis: ±105° B axis: ±180°	A axis: ±180° B axis: ±180°
Angular rotation step	5°	2.5°	2.5°
Max. applied torque	0.6 Nm	1.4 Nm	1.7 Nm
Max. extensions length	300 mm	450 mm	750 mm

Technical Characteristics	HP-L-10.6	HP-L-20.8
Laser	Visible red, class 2	Visible red, class 2
Standoff and depth of FOV	170 ± 30 mm	180 ± 40 mm
Width of FOV user selectable	24, 60, 124 mm	25, 51, 63, 130, 220 mm
Trange for specified accuracy	15 ~ 32 °C	15 ~ 32 °C
Sensor size L x W x H	134 x 72 x 60.5 mm	137 x 76 x 85 mm



Technical Characteristics	HP-C-VE
Nominal FOV size	6.5 mm x 5 mm
Nominal pixel size	approx. 8.5 µm
Optical magnification	x 0.73
Working distance	75 mm
Ring light configuration	2 rings, each with 4 sectors. 1 LED per sector on the inner ring, 2 LED per sector on the outer ring
Sensor size Ø x L	max. Ø75 mm x 137.5 mm (with TKJ mount)





## PROBE HEADS CONFIGURATIONS

	05.YY.05	07.YY.05	07.YY.07	09.YY.08	12.YY.10
HP-S-X3c	X	✓	✓	•	•
HP-S-X5	X	X	X	✓	✓
HP-S-X5 HD	X	X	X	•	•
HH-A-T 5°	•	•	•	X	•
HH-AS-T 5°	✓	•	•	•	•
HH-A-T 2.5°	•	•	•	•	•
HH-AS-T 2.5°	X	✓	✓	✓	✓
HH-AS-H 2.5°	X	X	X	•	•
HP-S-X3c	✓	✓	✓	•	•
HP-S-X5	X	X	X	✓	✓
HP-S-X5 HD	X	X	X	•	•
HH-A-T 5°	•	•	•	X	•
HH-AS-T 5°	✓	•	•	•	•
HH-A-T 2.5°	•	•	•	•	•
HH-AS-T 2.5°	X	✓	✓	✓	✓
HH-AS-H 2.5°	X	X	X	•	•
HP-S-X3c	✓	✓	✓	✓	✓
HP-S-X5	X	X	X	X	X
HP-S-X5 HD	X	X	X	X	X
HH-A-T 5°	•	•	•	X	•
HH-AS-T 5°	✓	✓	✓	✓	✓
HH-A-T 2.5°	•	•	•	•	•
HH-AS-T 2.5°	X	•	•	•	•
HH-AS-H 2.5°	X	X	X	•	•

Chrome Performance Level

Blue Performance Level

Green Performance Level

- X Unavailable
- ✓ Recommended
- Available

## GLOBALS: TECHNICAL CHARACTERISTICS

Mechanical Frame	X: Micromachined anodized light alloy extrusion Y: Integral dovetail guideways, machined into the table Z: Micromachined anodized light alloy extrusion		
Surface Plate	Material: Granite Flatness: according to DIN876/III  Part Locking: threaded inserts M8 x 1.25 Diagonally staggered hole pattern: GLOBALS 05.YY.05: X= 350 mm ; Y= 150 mm GLOBALS 07.YY.05: X= 300 mm ; Y= 300 mm GLOBALS 07.YY.07: X= 300 mm ; Y= 300 mm GLOBALS from 09.YY.08: X= 350 mm ; Y= 350 mm		
Sliding System	Air bearings on all axes		
Measuring System	METALLUR® linear scales. System Resolution: 0.005 µm		
Temperature Compensation	Extended temperature 16 - 26 °C: Multi-sensor technology Shop floor temperature 15 - 30°C: Structural multi-sensor technology		
Ram Counterbalance	Pneumatic, adjustable		
Controller	DC800 or DC800 I/O-Ready, IP54	DC800 or DC800 I/O-Ready, IP54	DC241, IP54
Supply Requirements	Power	100/120/220/240 V± 10% - 50/60 Hz - 1.6KVA	
	Air	0.5 MPa minimum - Class 4 according to ISO8573/1	
Consumption	Power	0.5 KVAh	0.35 KVAh
	Air	70 NI/min (for 05.YY.05); 90 NI/min (for all other models)	
Operating Specifications	Ambient temperature: 10 - 40 °C Relative humidity: 20% - 90 % non-condensing		

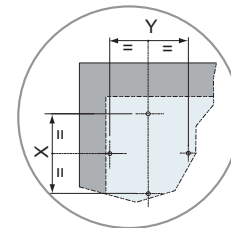

## GLOBALS: MINIMUM DOOROPENING REQUIREMENTS

Standard Size Frames	Machine maximum overall dimension	
	Width (mm)	Height (mm) <sup>1)</sup>
5.5.5 - 5.7.5	1095	1490
7.7.5 - 7.10.5	1340	1475
7.10.7	1340	1655
9.12.8 - 9.15.8 - 9.20.8	1540 <sup>2)/</sup> 1665 <sup>3)</sup>	2020 <sup>2)/</sup> 2065 <sup>3)</sup>
12.15.10 - 12.22.10 - 12.30.10	1965	2305

<sup>1)</sup>Minimum Height is listed w/o the CMM stand for Global 05.YY.05, 07.YY.05, 07.YY.07 series and w/o pedestals for the Global 09.YY.08 and 12.YY.10 series

Dimensions shown are from the highest point at the top of the CMM to the lowest point on the CMM as in shipped condition

Dimensions shown do not include lifting equipment

Dimensions shown are with 25 mm minimum clearance all around

<sup>2)</sup>For GLOBALS Green

<sup>3)</sup>For GLOBALS Blue and Chrome





# HEXAGON

MANUFACTURING INTELLIGENCE

Hexagon Manufacturing Intelligence helps industrial manufacturers develop the disruptive technologies of today and the life-changing products of tomorrow. As a leading metrology and manufacturing solution specialist, our expertise in sensing, thinking and acting – the collection, analysis and active use of measurement data – gives our customers the confidence to increase production speed and accelerate productivity while enhancing product quality.

Through a network of local service centres, production facilities and commercial operations across five continents, we are shaping smart change in manufacturing to build a world where quality drives productivity. For more information, visit [HexagonMI.com](http://HexagonMI.com).

Hexagon Manufacturing Intelligence is part of Hexagon (Nasdaq Stockholm: HEXAB; [hexagon.com](http://hexagon.com)), a leading global provider of information technologies that drive quality and productivity across geospatial and industrial enterprise applications.

-  COORDINATE MEASURING MACHINES
-  3D LASER SCANNING
-  SENSORS
-  PORTABLE MEASURING ARMS
-  SERVICES
-  LASER TRACKERS & STATIONS
-  MULTISENSOR & OPTICAL SYSTEMS
-  WHITE LIGHT SCANNERS
-  METROLOGY SOFTWARE SOLUTIONS
-  CAD / CAM
-  STATISTICAL PROCESS CONTROL
-  AUTOMATED APPLICATIONS
-  MICROMETERS, CALIPERS AND GAUGES
-  DESIGN AND COSTING SOFTWARE